

MOBILE SERVICE INTEGRATION

Multifunctional Mobile Service Sites

- Personalised form
- Outdoor advertising
- Novel lightning concepts
- Harnessing renewable energies

www.simex.ch/communication

The challenge:

The demands of mobile services networks are growing day by day - telecommunications are expected to work smoothly wherever we are. However, the development and maintenance of mobile services networks is not cheap! The gradual upgrade to new technologies means significant investments for mobile services within the next few years. The disappearance of roaming tariff rates and the high pressure of ever-increasing competition represent additional financial challenges for all in the sector.

Our solution:

SIMEX offers a uniquely advantageous concept for an optimised financing of telecommunications sites. Investing in a new communications site pays extra dividends with our solution: our camouflages can be individually designed to be used as advertising space. Additionally, the use of a wind turbine is possible to enable the site to become self-sufficient: supplying soundless and environmentally friendly energy. Our solutions can be easily and quickly installed - whether as new sites or as upgrades to existing installations. Individual shaping, advertising and illumination solutions give you complete flexibility and freedom with the design.



Our supply spectrum:

All camouflages are made of sustainable and ultra-lightweight material. Our sites are safe and easy to install and are integrated seamlessly at all levels into their surroundings.

We advise you on all questions of feasibility and present you with the optimal, custom-made solution for your telecommunications site! We are your all-inclusive service provider and partner starting with conceptual design to static calculations and production to the installation on site: competent, creative and sustainable.

Make an appointment for an individual consultation!

By e-mail ts@simex.ch or
mobile phone **+41 79 300 39 59**.

I am looking forward to our meeting,
Thomas Scheidegger

BLEND INTO THE BACKGROUND WITH YOUR PERSONAL CHOICE OF FORM

The challenge:

A new telecommunications site should be installed. Contract negotiations with the landowner are drawing near.

Our solution:

With its customised shape and design, the site cover can be installed rapidly and cost-effectively, integrating themselves inconspicuously into the immediate environment.

An elegantly camouflaged installation can serve to dissipate stakeholders' concerns, and acquisition and negotiations tend to become all of a sudden a lot easier. The design you choose can set yourself apart from the rest of the competition.

Also, already existing sites can be easily upgraded!



Get the most out of your STRIKING ADVERTISING SPACE

The challenge:

Adapting sites to new technologies and installing additional sites involve significant investment.

Our solution:

Not only can you select the form of cover that best meets your requirements in terms of design and surroundings, but we can print onto it any design you supply us with. The resulting advertising space guarantees attention and offers manifold creative potential!

Regular advertising revenues mean rapid return on your investment.



Outshine your competitors with our NOVEL LIGHTNING CONCEPT

The challenge:

The telecommunications site is to be installed in a central, highly visible location, e.g. in the middle of town or on a busy main road.

Our solution:

Individual illumination makes the cover also widely visible at night, raising the desirability of the advertising space and increasing advertising revenues.

A customised illuminated advertising solution increases the attractiveness of the site for promotional purposes and integrates the installation deep into the urban landscape.



POWER GENERATION WITH SUSTAINABLE ENERGY

The challenge:

You are in negotiations with a landowner, who would like to use the site as an advertising space for his company and places high value on their own sustainable image, too.

Our solution:

We install a soundless, highly efficient wind generator on top of the cover. The energy produced can be used to operate the site or to supply the local electricity network.

The use of renewable energy conveys a positive image and additionally heightens the attractiveness of the proposition: the power required to run the site is produced free of charge for the user.

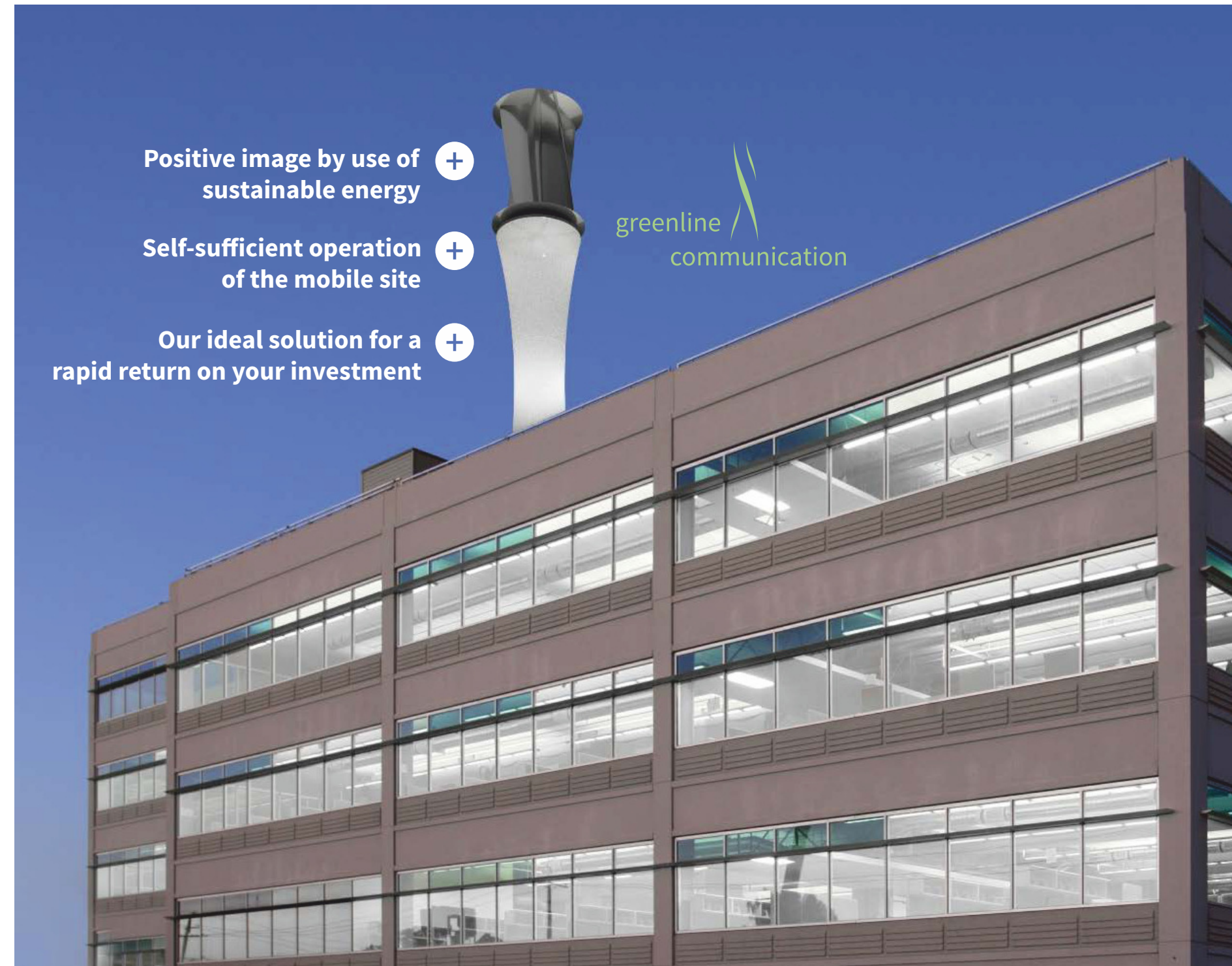

We find the right solution for you!
Your advantages:



A shape for all environments +



A shape fit for its surroundings +

Advertising print +

Illumination +

Ideal integration of the mobile site into its surroundings

Facilitate contract negotiation with the landowner

Faster acquisition processes

Stand out from the competitors, thanks to the site's highly individual form

Rapid return on investment by leveraging the cover space for advertising

Extra return on your investment by use of illumination features

Boost your sustainable image by standing out as a producer and user of alternative energies with our solution.

Optimal savings on site operation thanks to its self-generated power production.



+ Personal choice of form

+ Advertising print



+ Select from a range of covers

+ Advertising print

+ Illumination

+ Power supply with sustainable energy

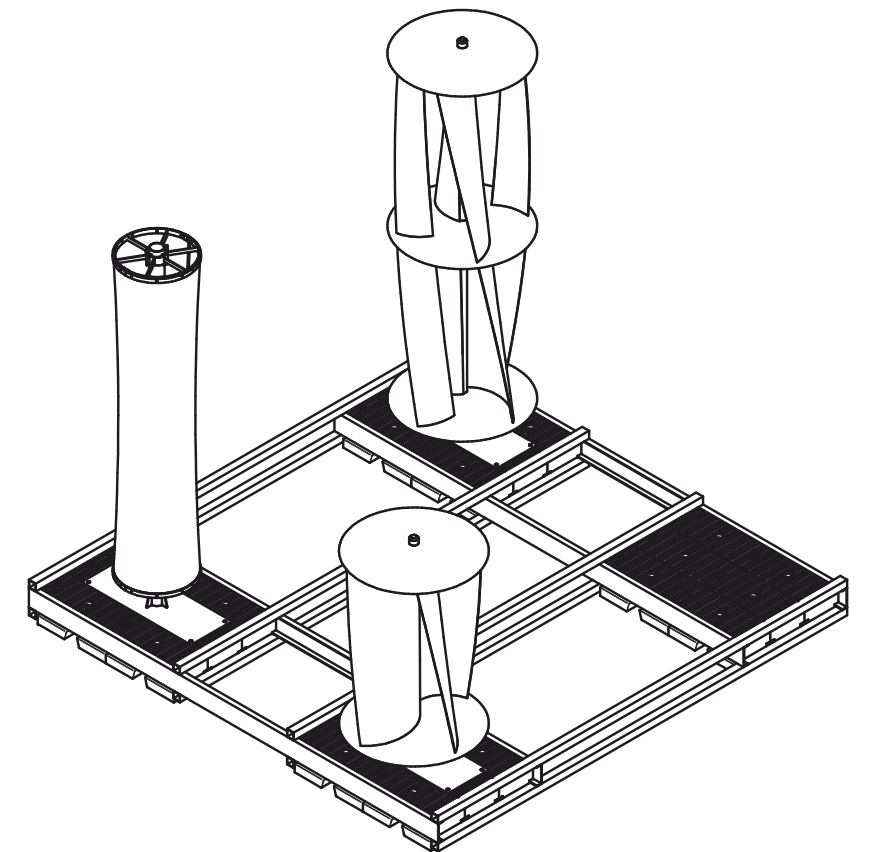
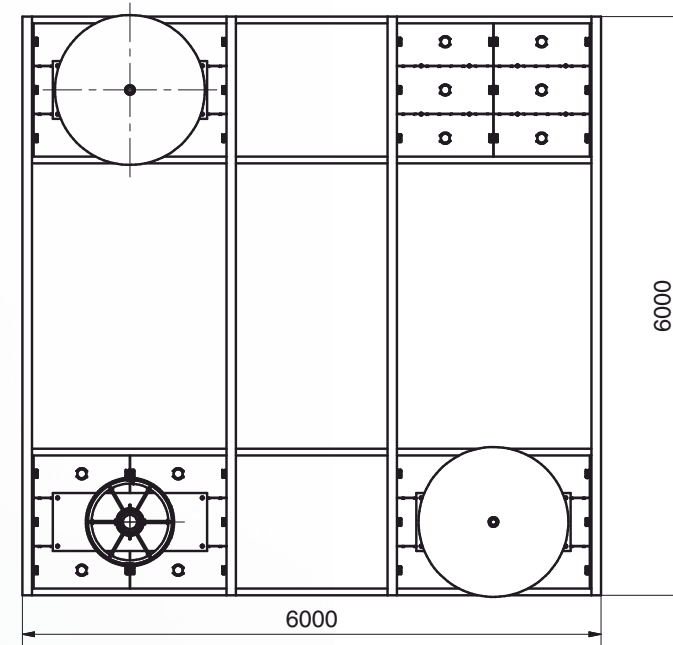
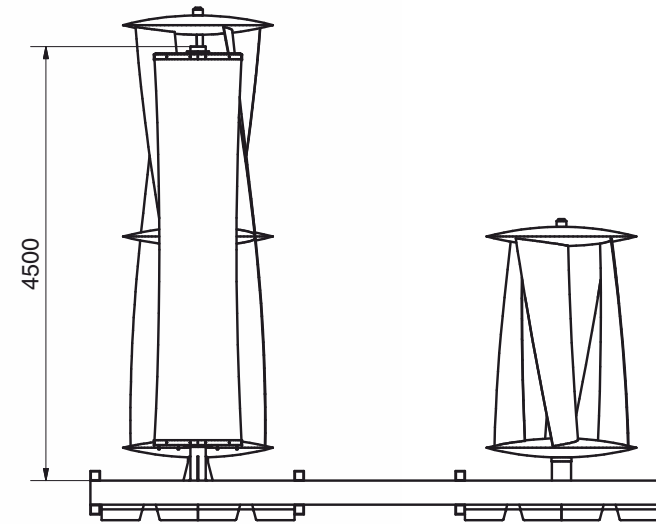

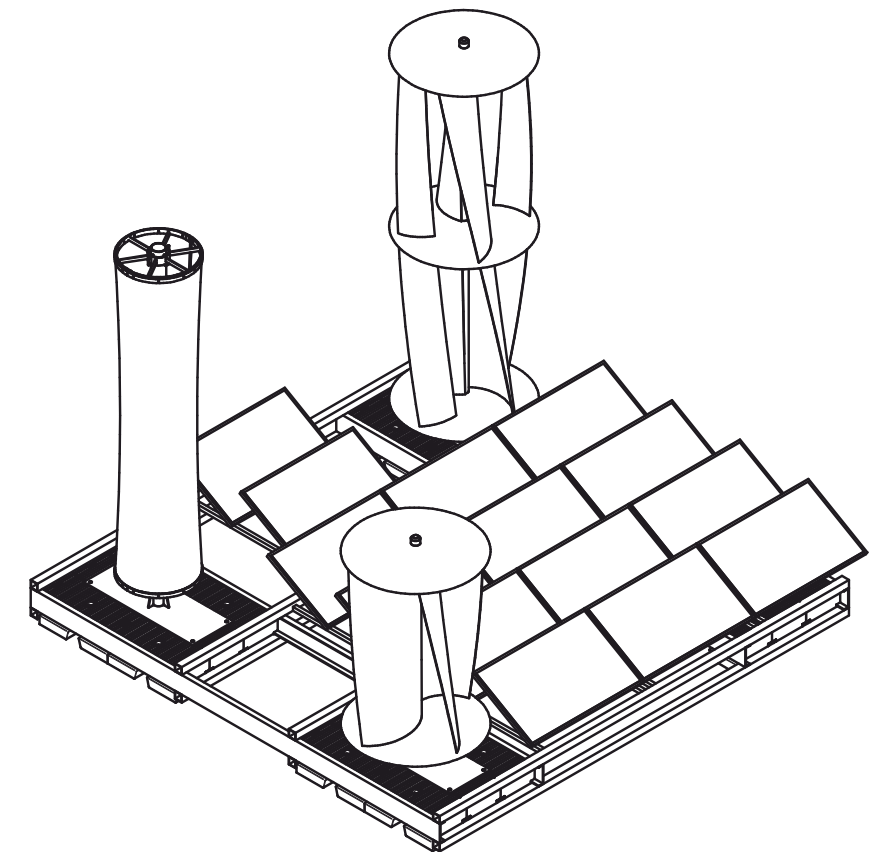
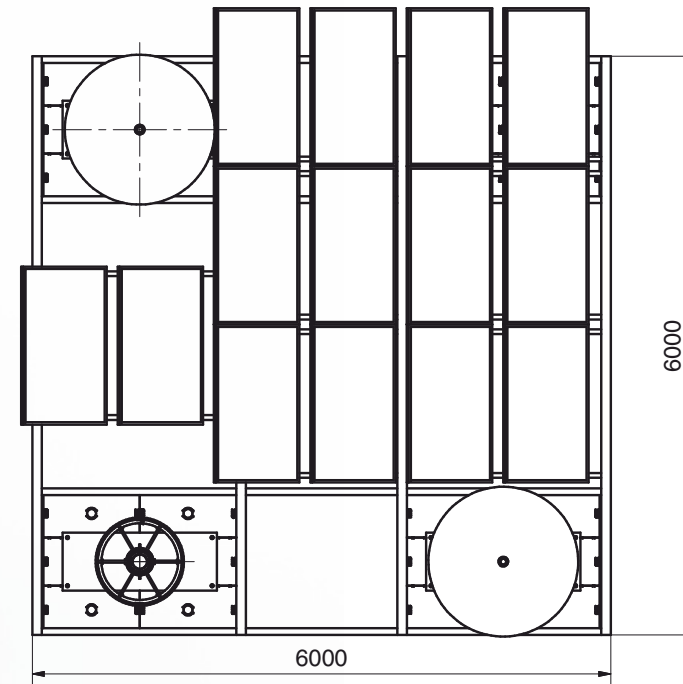
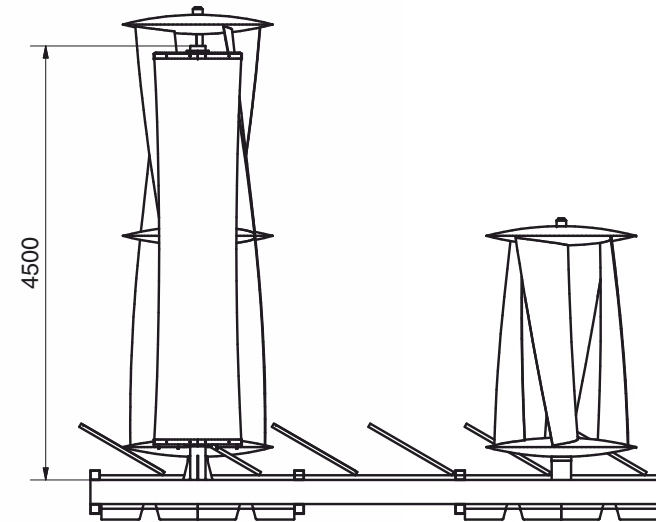
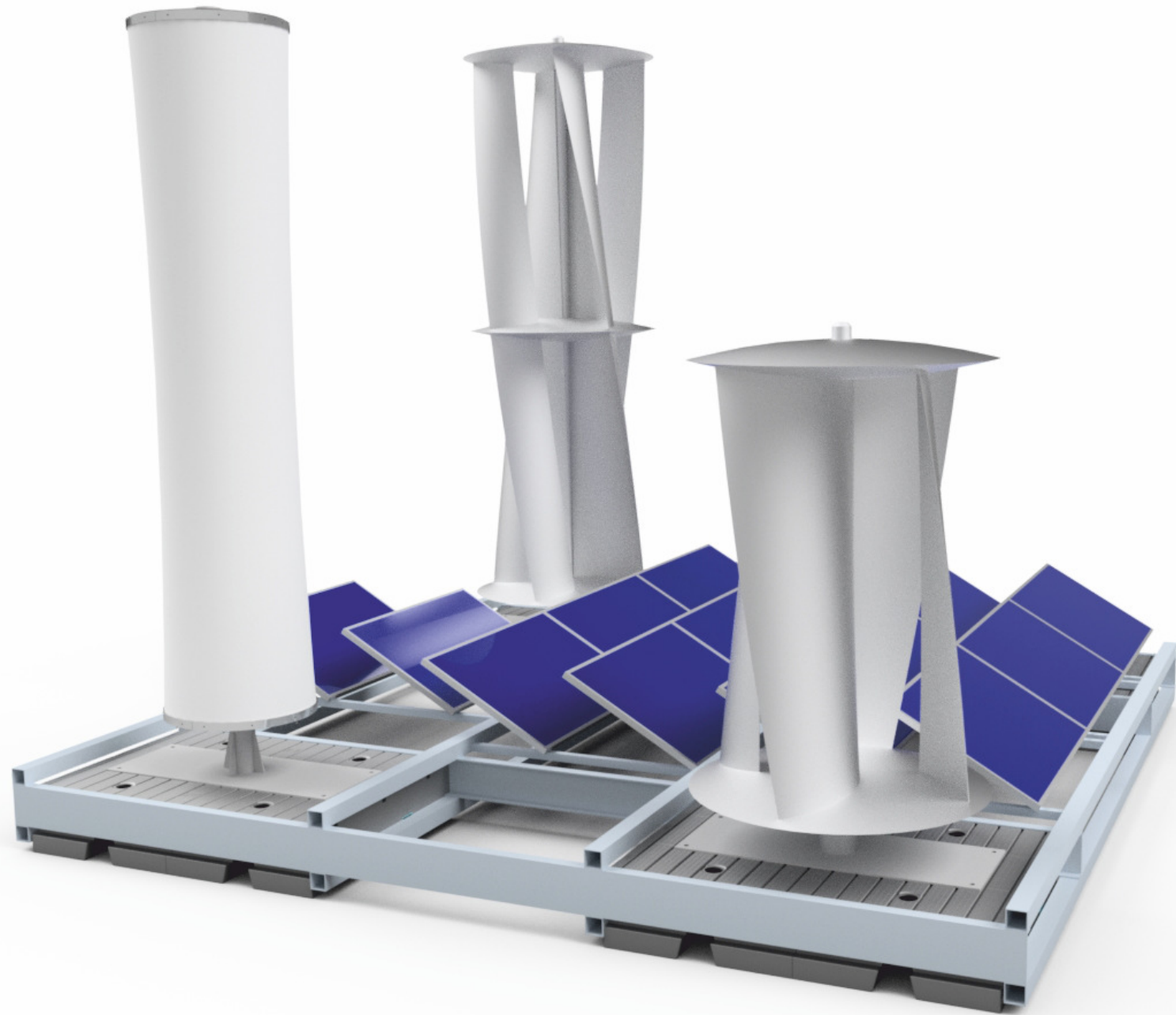

HELIX WIND TURBINE WIND-OF-CHANGE



Our sustainable solution for a rapid return on investment in your mobile site: the robust turbine consists of ultra-lightweight components and spins absolutely soundlessly - whether in a light breeze or in strong gusts of wind.

The Helix-construction provides the optimum sail area for the wind in every position. Choose your type:



1 kW nominal output

Ø 1,750 m

Start speed 4 km/h

max. output 1,4 kW

initial power output 7 km/h

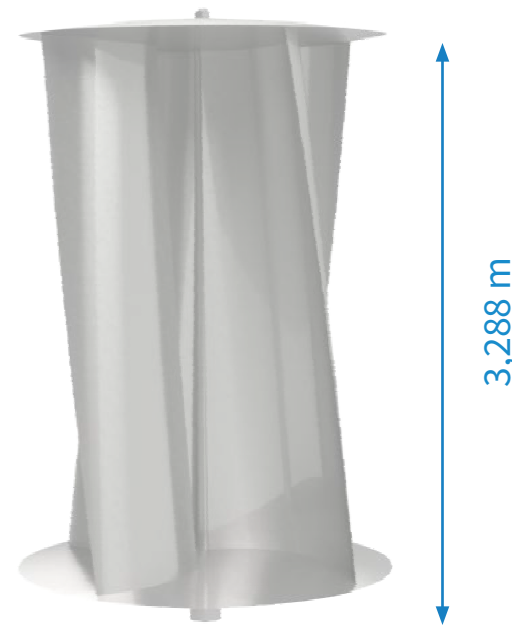

2 kW nominal output

Ø 2,331 m

Type in construction

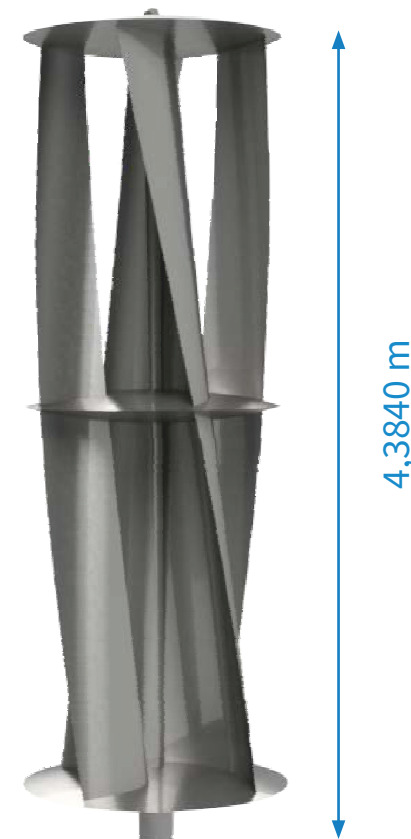

3 kW nominal output

Ø 1,750 m

Start speed 5 km/h

max. output 3,5kW

initial power output 7 km/h

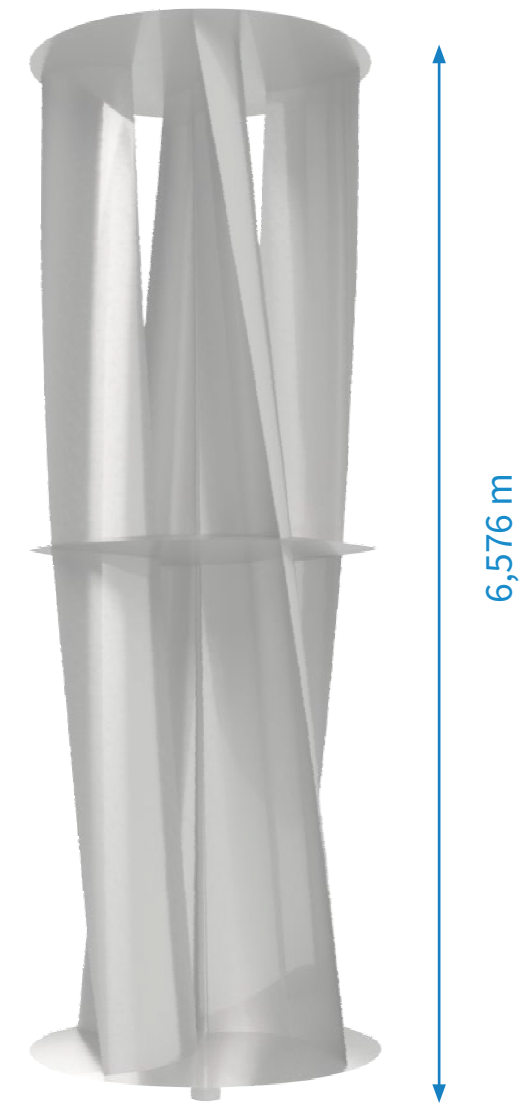

6 kW nominal output

Ø 2,331 m

Type in construction

greenline
communication



SIMEX 
communication solutions

SIMEXtelecom GmbH
Hostet 18
CH-9050 Appenzell

Tel. + 41 (0) 71 536 08 05
Fax + 41 (0) 34 408 80 52
info@simex.ch



© 2017 SIMEXenergy GmbH